

Osprey Platform Assembly Guide



Menunkatuck Audubon Society

Rev 1.0

Menunkatuck Audubon Society is a local chapter of National Audubon Society. We serve the shoreline towns of West Haven, New Haven, East Haven, Branford, Guilford, and Madison, Connecticut. We have a 32-year record of conservation, education, and advocacy.

Menunkatuck's conservation efforts allow us the opportunity to give back to nature and restore the delicate balance of the ecosystems in our area. Our aim is to minimize and mitigate the damage from human impact. This installation guide is designed to help other Audubon chapters and individuals that would like to install new, or repair existing, osprey platforms.

Learn more at:
menunkatuck.org

Menunkatuck Audubon Society
PO Box 214
Guilford, CT 06437

Menunkatuck Audubon Society is a 501c3 organization. All donations are tax deductible as allowed by law and fund our conservation work and programming.

Major Components

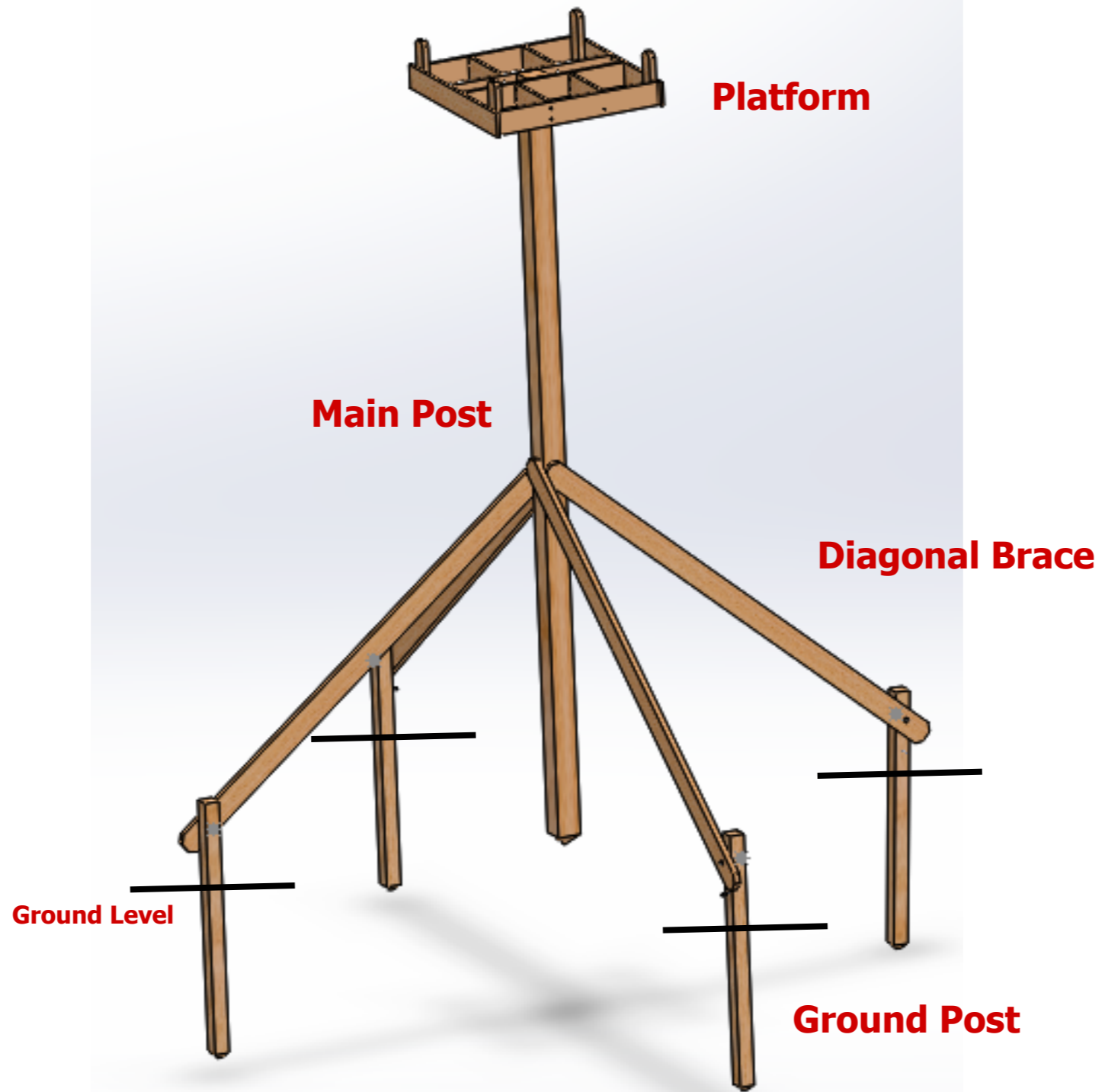

Steps

The platform is assembled prior to installation and then added to the main post on-site.

Pilot holes should be used for all screws to prevent splitting.

Materials

All wood that could make contact with the ospreys is cedar. We do not recommend pressure treated wood.

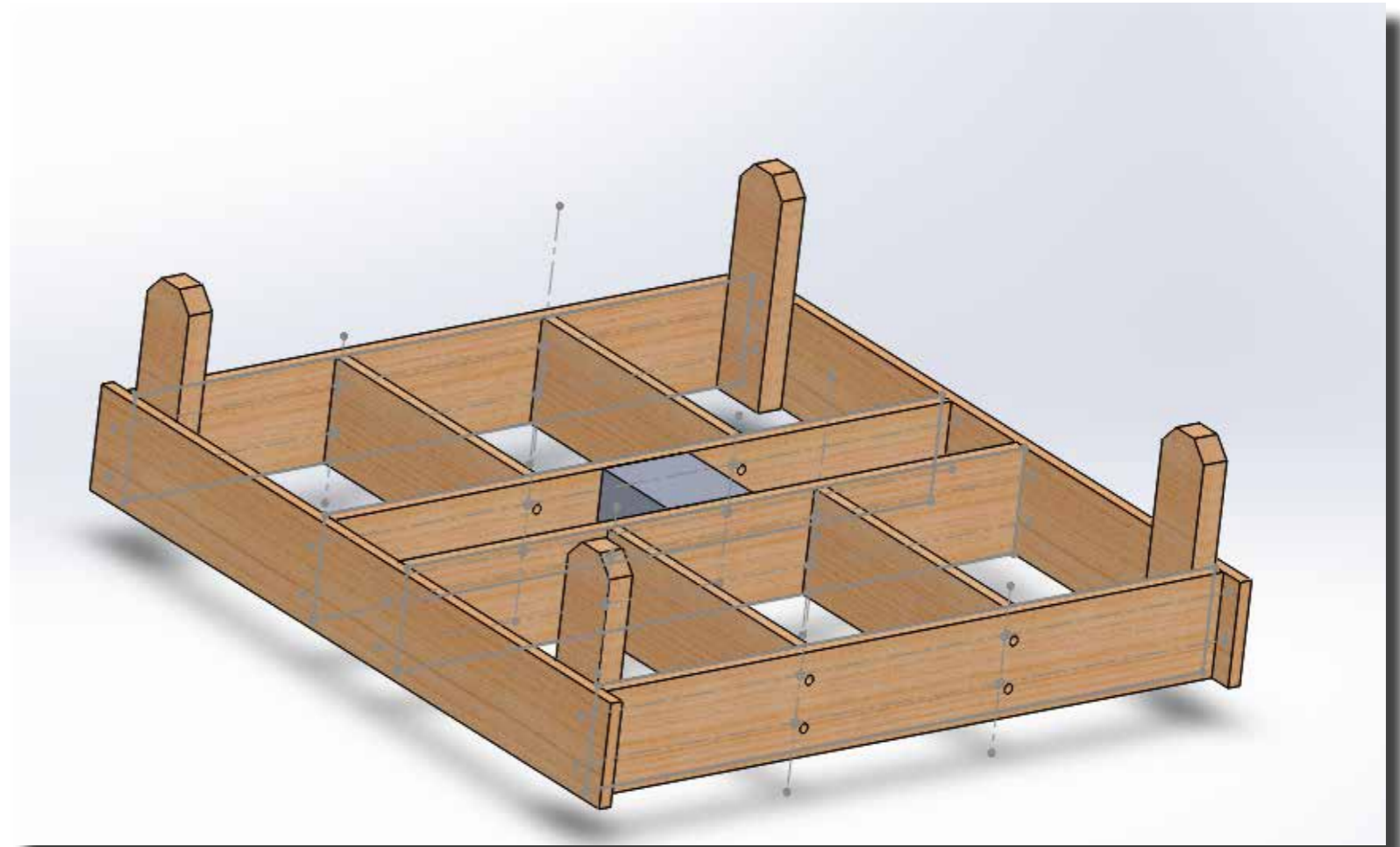

Steps

1. Cut 1x6 cedar to the following lengths.

Long Side: 43" Qty:2

Short Side: 40" Qty:4

Middles: 17.25" Qty:4

Materials

1"x6" x 14' Cedar#3 -rough
on one side Qty: 2

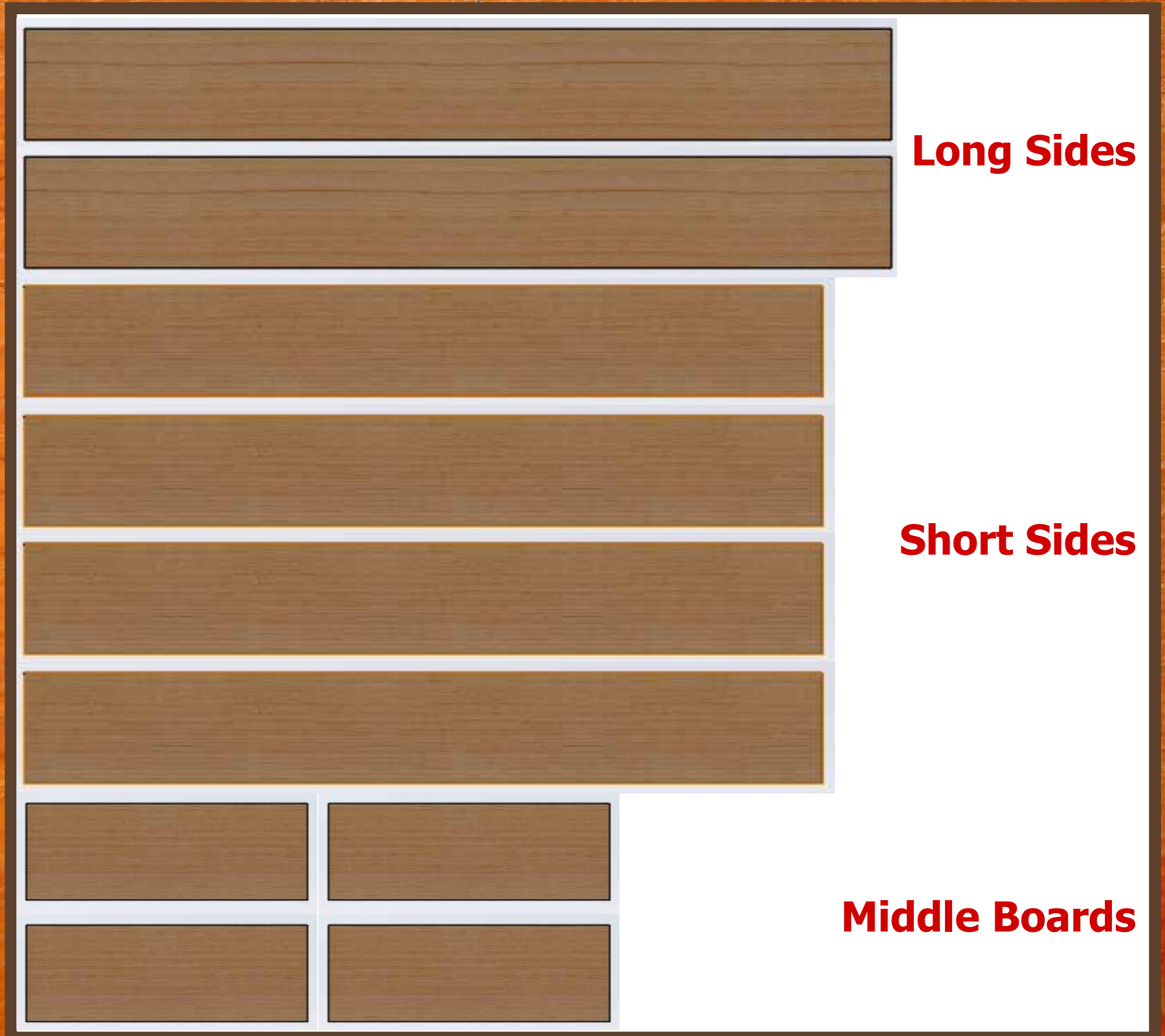

Steps

1. Cut four posts 12" long
2. Notch top two corners of post at 45 degrees.

Post: 12" Qty:4

Materials

2"x4"x8' Cedar Qty: 1



Corner Posts

Steps

Pilot holes should be used to prevent splitting.

1. Position the middle boards 13 inches (on center) from the ends of a short side board.
2. Secure each middle board with two lag screws with washers.
3. Attach the second short side board with lag screws.
4. Make a second ladder structure.

Materials

- 1/4"x3" Galvanized lags screws Qty: 16
- 1/4" galvanized washers Qty: 16

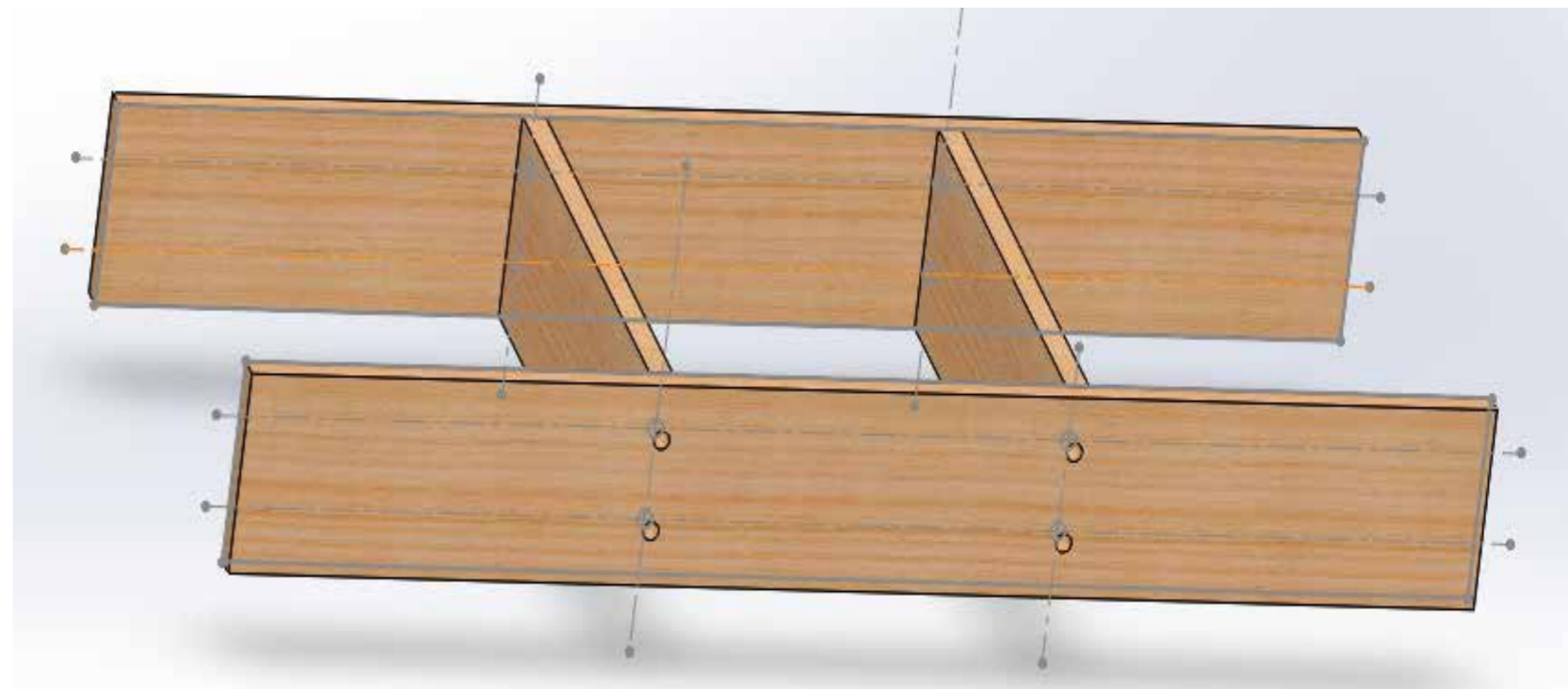
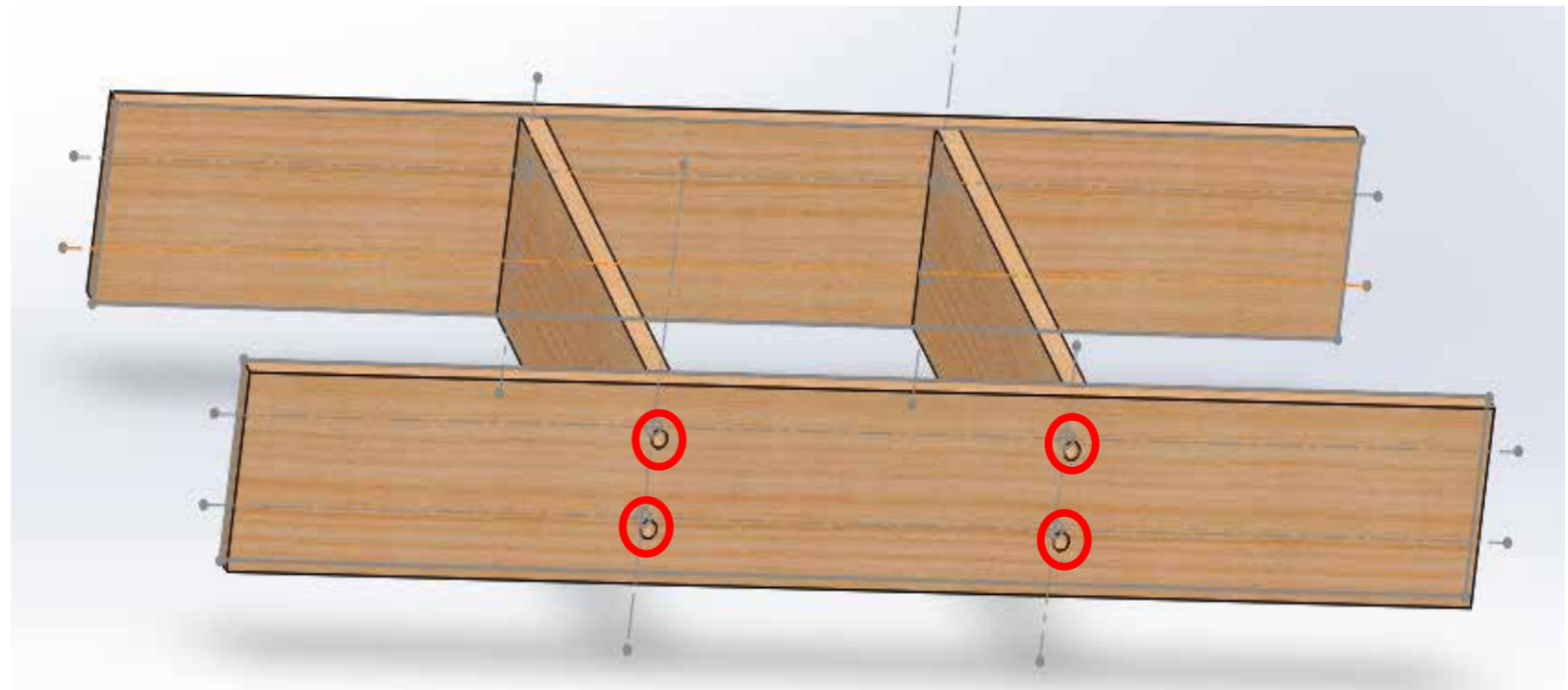

Steps

Pilot holes should be used for all screws to prevent splitting.

1. Use scrap pieces of 2x4 to help position the two ladder structures so they are the same width as the main post.
2. Center the long sides across the ladder structures and secure with two lag screws through each center board. *(red dots)*
3. Repeat on other long side.

Materials

- 1/4"x3" Galvanized lag screws Qty: 8
- 1/4" Galvanized washers Qty: 8

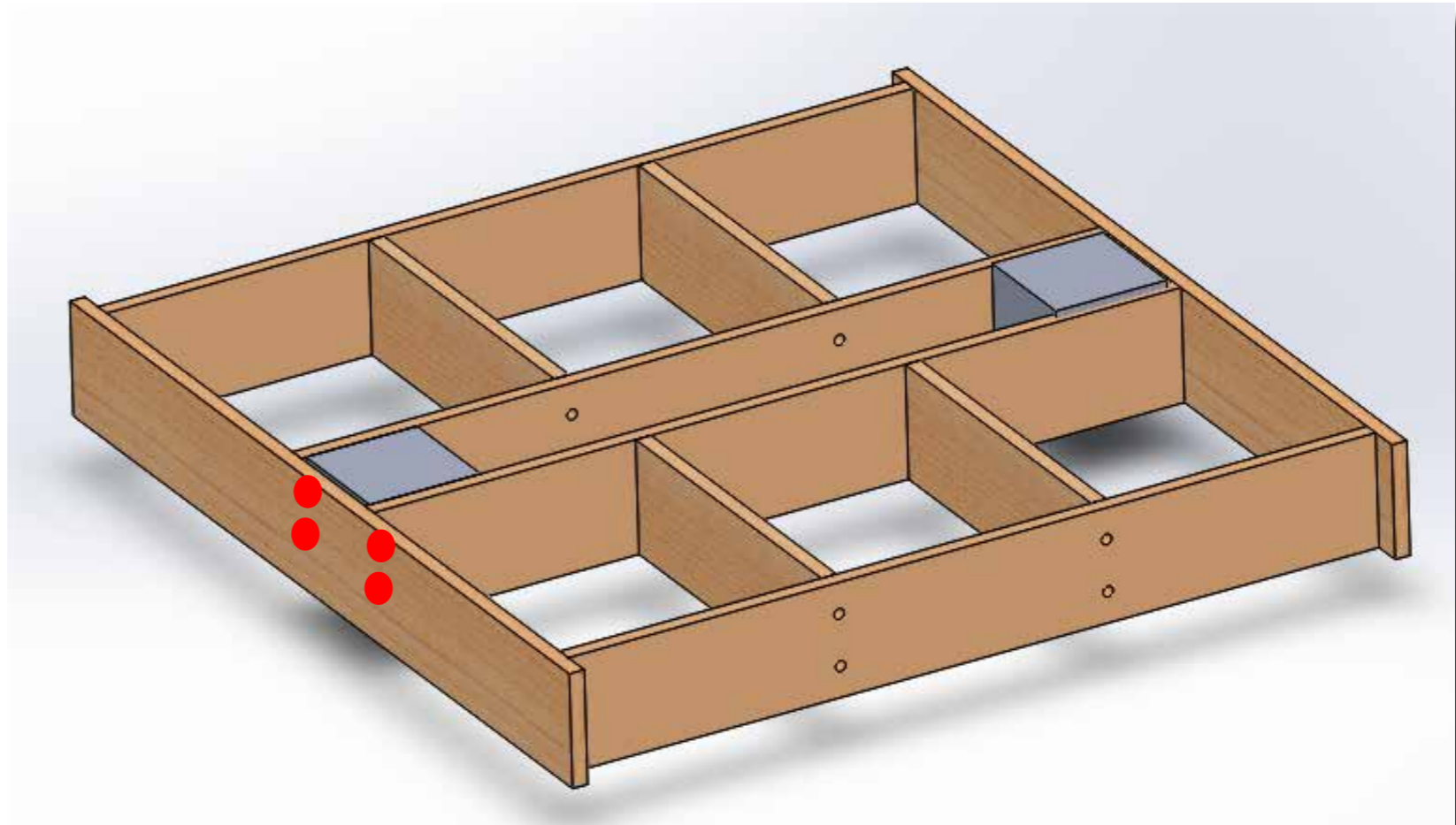

Steps

Pilot holes should be used for all screws to prevent splitting.

1. Position a corner post to fit squarely in each corner of the platform.
2. Secure posts with two lag screws and washers on each side.

Materials

- 1/4"x3" Galvanized lag screws Qty: 16
- 1/4" Galvanized washers Qty: 16

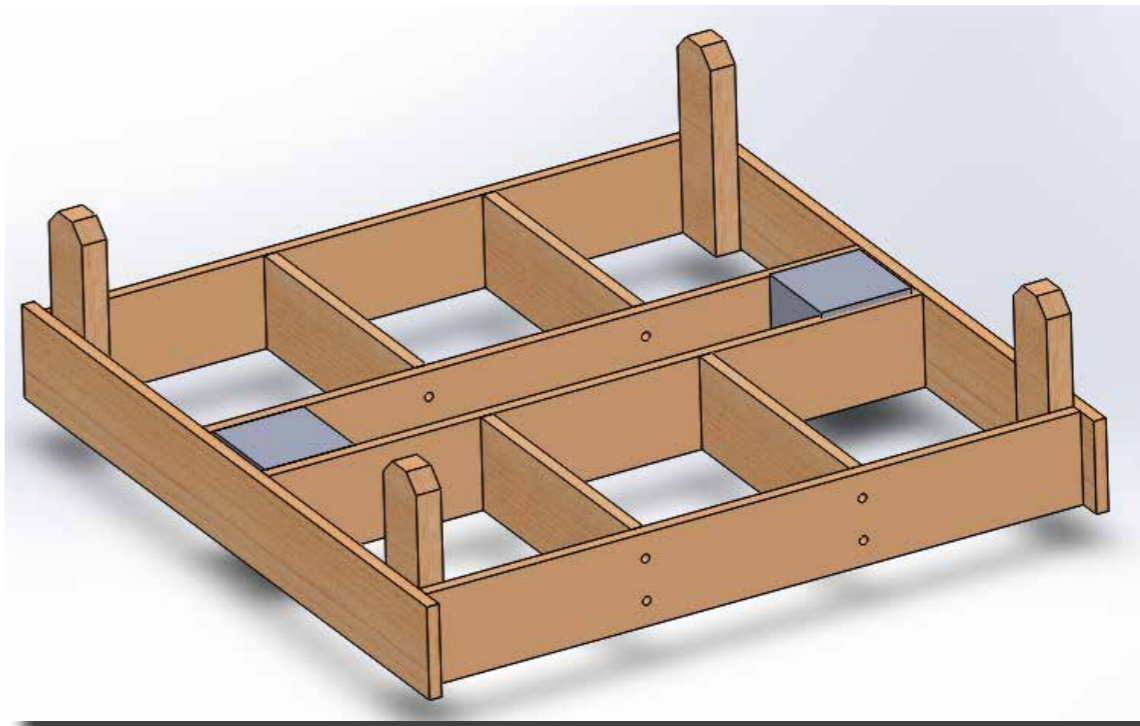

Steps

1. Drill a $\frac{3}{8}$ " hole in the center of each side of the platform to attach the metal support bracket.
2. Insert a hex bolt with washers through hole. The nut should be on the inside of the platform and there are two washers on each end.

The support bracket will be attached on-site. The hole for the bottom of the support bracket is drilled once the platform is attached to the main post to ensure it aligns properly.

Materials

- $\frac{3}{8}$ "x2" Galvanized hex bolt Qty: 4
- $\frac{1}{2}$ " Galvanized washer Qty: 8
- $\frac{3}{8}$ " Galvanized washer Qty: 8
- $\frac{3}{8}$ " Galvanized nuts Qty: 4



Steps

1. Drill a $\frac{3}{8}$ " hole in each end of the metal bar.
2. Bend 45 degree angles on each end of the metal bar. The bent end should be about 2" long. (Note that each bend goes in the opposite direction).
3. Paint the bracket to prevent rusting.

Materials

- $\frac{3}{16}$ " (or $\frac{1}{4}$ ") x1"x30"
Steel flat bar Qty: 4



There is 1 metal bracket per side.

Steps

1. Add a piece of scrap metal flashing to protect the end grain of the main post.
2. Use 2 sheet metals screws with washers to secure the flashing. Make sure both screws are on the same board.

Materials

- 26 Gauge (or 22 Gauge) Sheet metal 10"x10" (this can be scrap from baffle)
- 1" #8 Sheet metal screws with hex heads Qty: 2
- #8 Fender washers Qty: 2

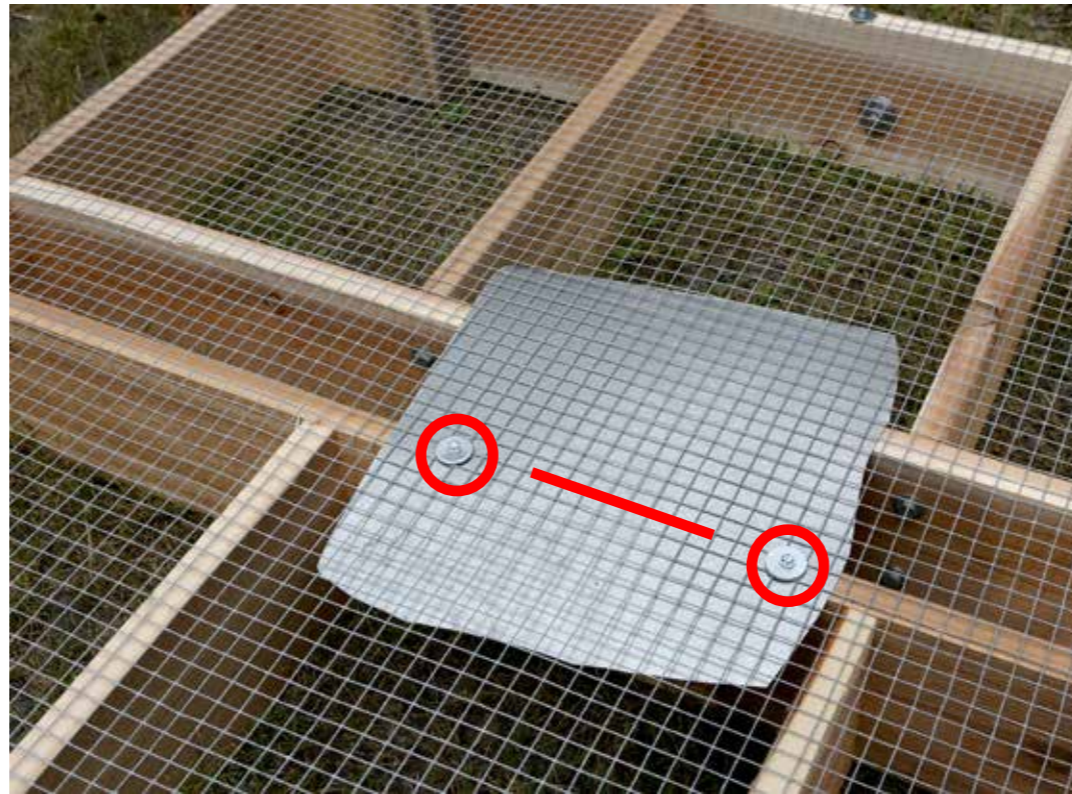

Steps

1. Position hardware cloth over platform.
2. Cut notches in corners to go around corner posts.
3. Secure hardware cloth with sheet metal screws and washers around perimeter. (3 per side)
4. Trim any hardware cloth that extends over edge of platform.

Materials

- 1/2" Hardware cloth (42" x42")
- 1" #8 Sheet metal screws with hex heads Qty: 12
- #8 Fender washers Qty: 12

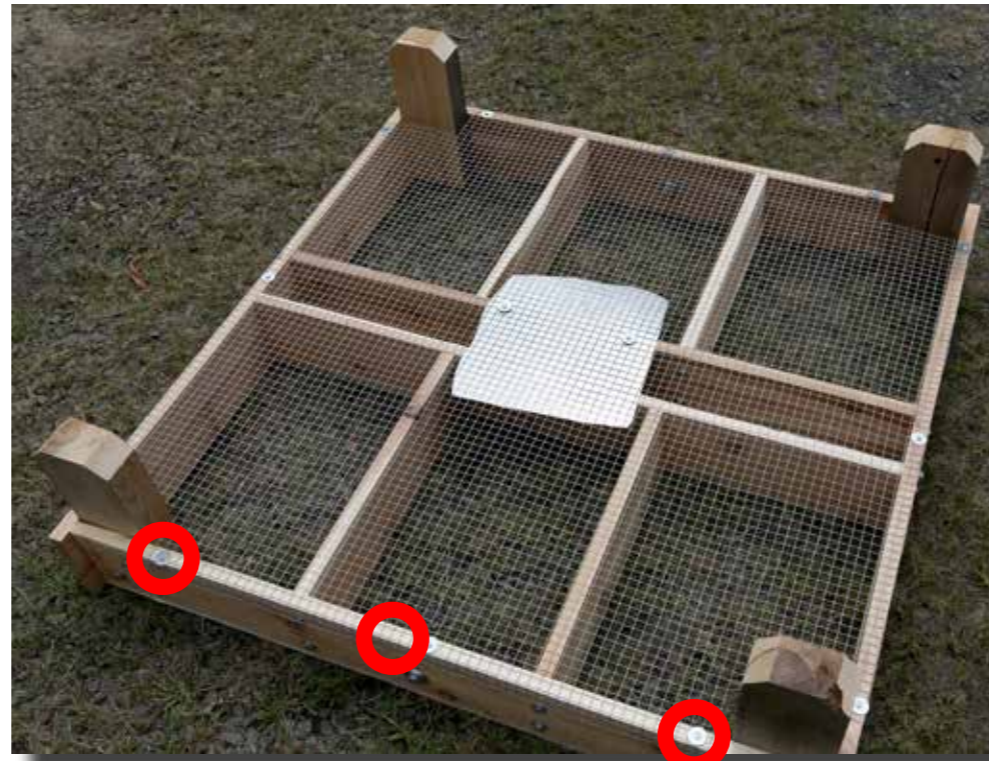

Steps

1. Mark a line 4 feet from the bottom of the post. (this is how deep the pole will go in the ground).
2. Measure 9'-8" from bottom of pole and drill a 1/2" hole through post.
3. Rotate post 90 degrees.
4. Measure 9'-10" from bottom of pole and drill a 1/2" hole through post.
5. Cut 45 degree bevels on bottom of post.

Materials

4"x4"x16' Pressure Treated
Qty: 1

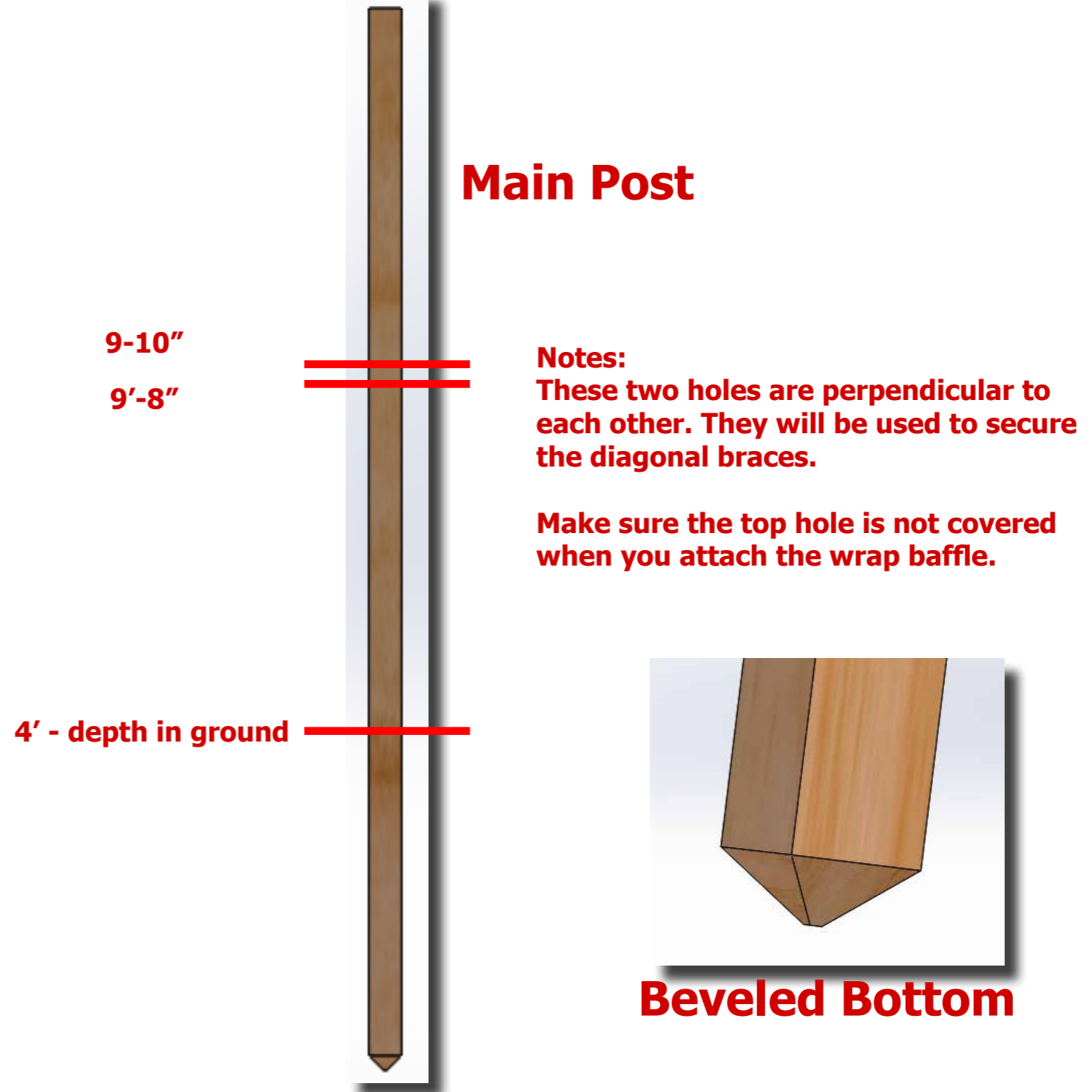

Steps

1. Position the bottom edge of the sheet metal 9'-10" from the bottom of the main post (**don't cover hole**). Align the long edge with the post edge.
2. Secure with 5 nails.
3. Use a wooden mallet to bend the metal around face of post.
4. Rotate post 90 degrees.
5. Secure with nails.
6. Continue to wrap and nail post until flashing overlaps.

Materials

- 16"x48" - 26 gauge galvanized metal (painted)
Qty: 1
- 1½" Roofing nails
Qty: 20



Steps

1. Center the main post in the platform so that it just touches the sheet metal end grain cap.
2. Drill a 1/2" hole through the center of both 1x6 cedar boards and the main post.
3. Mark the orientation of the platform and pole so that during assembly you can line up the hole.

Materials

- Completed platform
- Main post



Steps

1. Cut 4x4 posts to 5 foot lengths.
2. Cut 45 bevel cuts on bottom of each post to make it easier to drive them in the ground.

Materials

- 4"x4"x10' Pressure Treated
Qty: 2

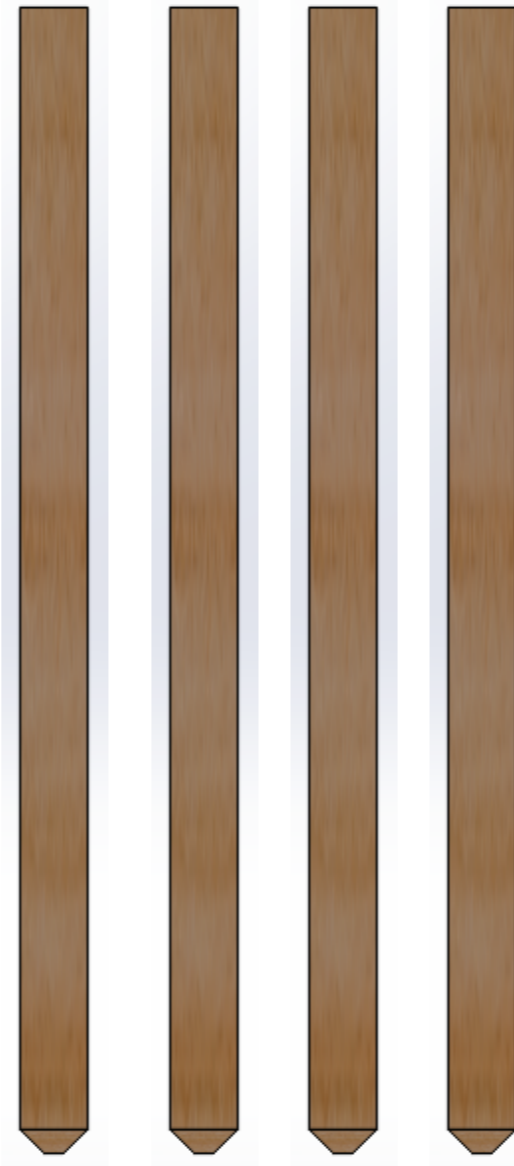

Ground Posts

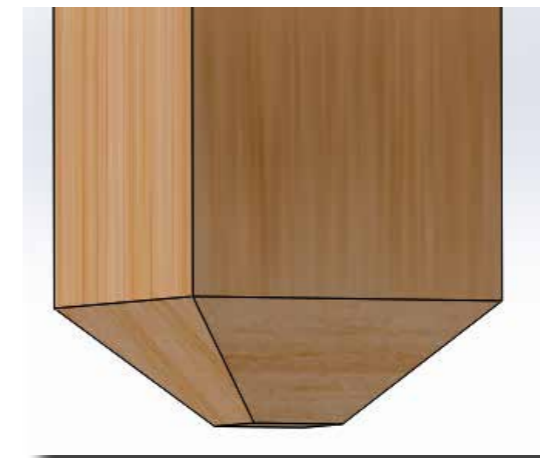

Beveled Bottom

Steps

1. Cut 45 degree notches on all four corners of the 2x4.

Materials

2"x4"x10' Pressure Treated
Qty:4

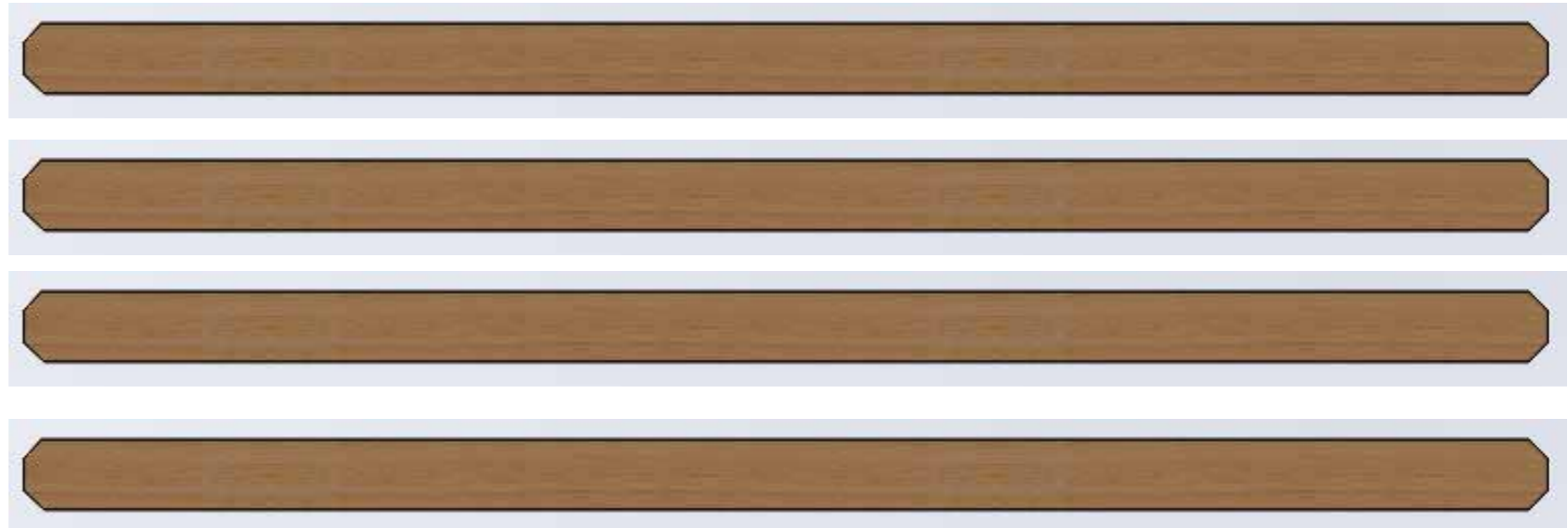

Braces

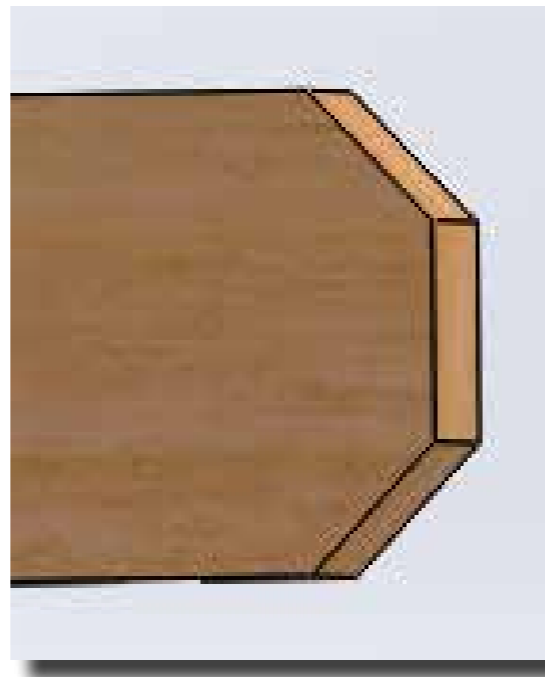

Notched Corners

- 1/2"x8" Galvanized hex bolt with two 1/2" washers and nut
- 1/2"x7" Galvanized hex bolt with two 1/2" washers and nut
- 1/2"x6" Galvanized hex bolt with two 1/2" washers and nut
- 3/8"x2" Galvanized hex bolt with four washers (two 1/2" & two 3/8") and nut
- 3/8"x2 1/2" Galvanized lag screw with 3/8" washer
- 1/4"x3" Galvanized lag screw with 1/4" washer
- 1/4"x2" Galvanized lag screw with 1/4" washer
- 1/4"x1/2" Zinc bolt with washer and nut
- 1" #8 Sheet metal screw, hex head with fender washer
- 1 1/2" Roofing or joist nails

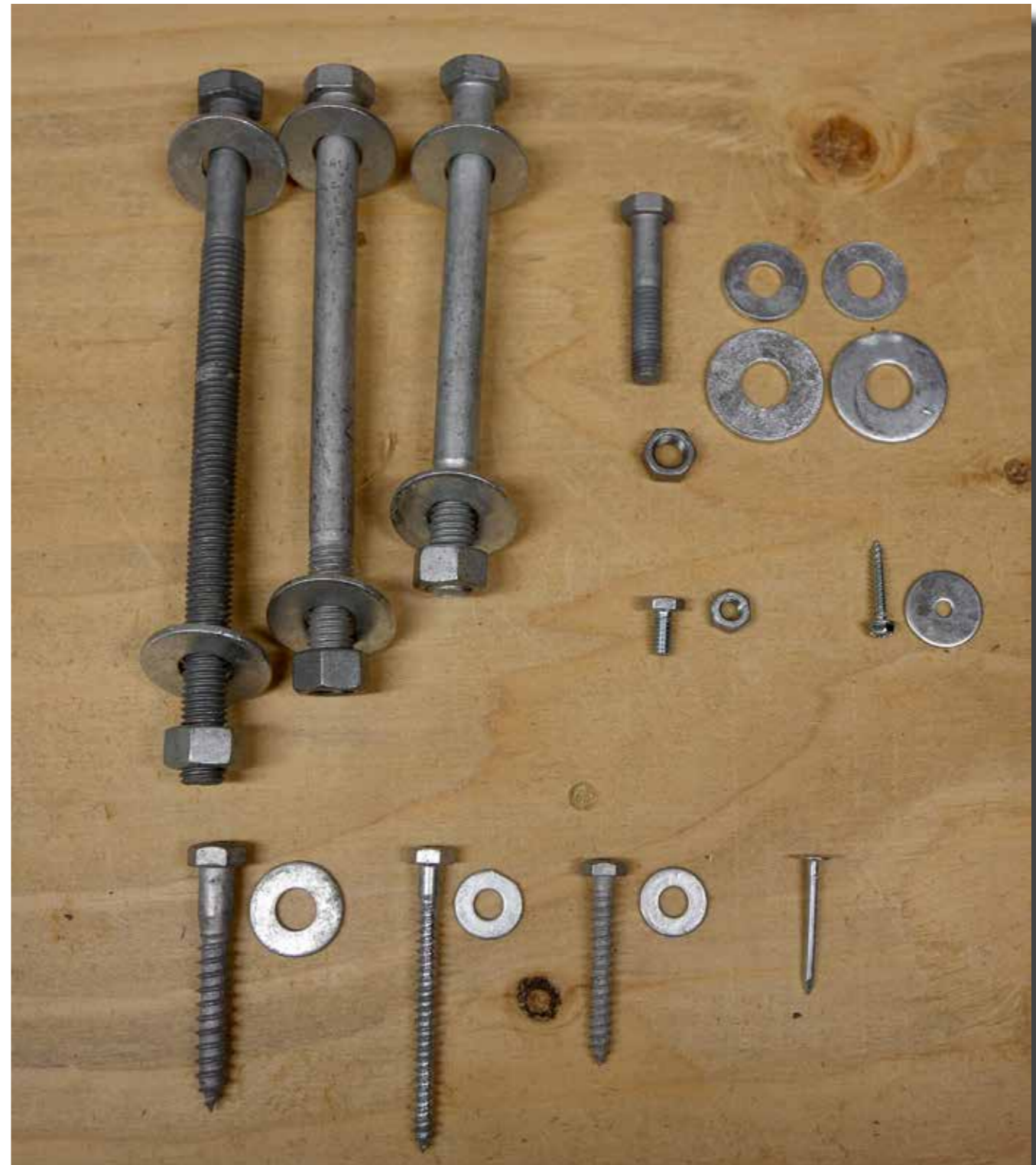

Description	Quantity	Used for
1/2"x8" Galvanized hex bolt	2	Secure diagonal braces to main post
1/2"x7" Galvanized hex bolt	1	Secure platform to main post
1/2"x6" Galvanized hex bolt	4	Secure diagonal braces to ground posts
3/8"x2" Galvanized hex bolt	4	Secure metal support straps to platform
3/8"x2 1/2" Galvanized lag screw	4	Secure metal support straps to main post
1/4"x3" Galvanized lag screw	40	Assembly of platform
1/4"x2" Galvanized lag screw	4	Secure round baffle to main post
1" #8 Sheet metal screws, hex head	14	Secure hardware cloth and metal end cap to platform
1 1/2" Roofing or joist nails	20	Secure metal wrap baffle to main post
1/4" Galvanized washer	44	
1/2" Galvanized washer	22	
3/8" Galvanized washer	8	
3/8" Galvanized nut	4	
1/2" Galvanized nut	7	
#8 Fender washers	14	
Baffle 30"	1	(see separate instructions for making baffle)
22 or 26 Gauge sheet metal 16"x48"	1	Pole wrap baffle
22 or 26 Gauge sheet metal 10"x10"	1	Main pole end grain cap
3/16" (or 1/4") x1"x30" Steel flat bar	4	Support brackets
2x4 8 Foot Cedar	1	Platform corner posts (do not use pressure treated - osprey contact surface)
1x6 14 Foot Cedar #3 one-side rough	2	Platform
4x4 16 Foot Pressure treated	1	Main post
4x4 10 Foot Pressure treated	2	Ground posts
2x4 10 Foot Pressure treated	4	Diagonal braces
Sticks 24"-30" (qty: 30) and wood chips		Material for a starter nest (2 buckets)
Cedar perch pole 10-12'	1	Used for adults to perch (look for old dead cedar tree)

Steps

It takes about 1.5 hours to install the platform.

Carry all materials to site location.

Keep mud and salt water away from power tools.

Tools needed:

- Post pounder (or post hole digger and shovel)
- 4' Bubble level
- 8' Step ladder
- 10' Step ladder
- 8" C-clamp
- Hammer
- Power drill with spare battery
- Drill bits: 1/4", 1/2"
- Ratchet wrench with sockets: 7/16", 9/16", 3/4"
- Box wrenches: 7/16", 9/16", 3/4"
- Battery sawsall or hand saw



Steps

1. Using a pounder, drive the main post into the ground until it reaches the four foot mark you made on the post. Try to keep the post as vertical as possible, but it does not have to be perfectly plumb at this stage.

Alternately, use a post hole digger to dig a four foot deep hole. Try to keep the hole as narrow as possible. Insert the main post and then back fill the hole, trying to keep the pole vertical.



Steps

1. Attach two of the diagonal braces on opposite sides of the main post. Secure the braces loosely using a 8" bolt with washers on both ends through the pre-drilled holes.
2. Position one ground post at the end of each brace. The brace should extend about 2 inches beyond the ground post.



Steps

1. Using a pounder, drive the ground post into the ground until 12-15 inches remain exposed. Keep the post as vertical as possible.

Alternately, use a post hole digger to dig a 3½-4 foot deep hole. Try to keep the hole as narrow as possible. Insert the ground post and then back fill the hole, trying to keep the pole vertical.



Steps

1. Using a C-clamp, lightly clamp the diagonal brace to one of the ground posts.
2. Use a 4-foot level to plumb the main post.
3. Tighten the C-clamp.
4. Drill a ½" hole through the diagonal brace and ground post.
5. Insert a 6" bolt with washers on both ends, and tighten to secure. Make sure main post remains plumb.
6. Repeat this process for the opposite ground post.



Steps

1. Lightly, secure the second set of diagonal braces to the main post with a 8" bolt with washers on both ends.
2. Position one ground post at the end of each brace. The brace should extend about 2 inches beyond the ground post.
3. Using a pounder, drive the ground post into the ground until 12-15 inches remain. Keep the post as vertical as possible.



Steps

1. Using a C-clamp, lightly clamp the diagonal brace to one of the ground posts.
2. Use a 4-foot level to plumb the main post.
3. Tighten the C-clamp.
4. Drill a ½" hole through the brace and ground post.
5. Insert a 6" bolt with washers on both ends, and tighten to secure. Make sure main post remains plumb.
6. Repeat this process for the opposite ground post.



Steps

1. Slide the baffle over the main post until it just touches the post wrap baffle.
2. Secure the baffle with four $\frac{1}{4}$ "x2" galvanized lag screws with washers. Check to make sure the baffle is level as you install screws.



Steps

1. Place the platform on top of the main post. Center the platform and align the marks you made when pre-drilling the hole (note the hole will only align in this orientation).
2. Align the pre-drilled holes in the platform with the pre-drilled hole in the main post.
3. Secure the platform with a 7" bolt with washers on both ends.



Steps

1. Remove the nut and washers from the 2" bolt in the center of each side of the platform.
2. Attach a metal support bracket on the inside of each bolt and secure loosely.
3. Position the bottom of the metal support bracket so that it is parallel to the main post.
4. Pre-drill a 1/4" hole through the bracket where it meets the main post.
5. Secure the bottom of the metal support bracket with a 2 1/2" lag screw and washer.
6. Tighten the top bolt on the platform.
7. Repeat for remaining three brackets.



Steps

1. Dump buckets of medium size branches and wood chips on top of platform to act as a starter nest.



Steps

1. Using post hole diggers, dig a three foot hole about 15'-20' away from the main post.

2. Insert a 10'-12' cedar tree post (do not use any pressure treated lumber as the adult birds often eat on this pole).

3. Backfill the hole.

The adults use this perch instead of sitting on nest.



Steps

1. Take a group photo of your outstanding work.
2. Submit your photo to the local newspaper.



photo shows optional perch bar